

# **A Review of Developments in Electrical Battery, Fuel Cell and Energy Recovery Systems for Railway Applications**

**A Report for the Scottish Association for Public  
Transport**

David Murray-Smith

Honorary Senior Research Fellow  
and Emeritus Professor of Engineering Systems and Control,  
James Watt School of Engineering, University of Glasgow

**Email:** [David.Murray-Smith@glasgow.ac.uk](mailto:David.Murray-Smith@glasgow.ac.uk)

30<sup>th</sup> November 2019

**Abstract:** This report outlines the current status of batteries, hydrogen fuel cells and short-term energy storage systems for railway and tramway applications. The report includes discussion of issues associated with regenerative braking and the recovery of energy that would otherwise be dissipated as heat during braking. As well as feeding energy back to the supply grid, as in the case of conventional electrified rail systems, energy recovery may also be achieved using batteries, super-capacitors, flywheels or hydraulic devices and developments in each of these areas are reviewed. The advantages of hybrid systems that involve combinations of different power sources and energy storage methods are emphasised and some associated design optimisation issues are discussed. For each of the developments mentioned, there is a brief account given of some transport applications in the United Kingdom and elsewhere. This is a rapidly developing field and operating experience with vehicles currently entering service in various countries will provide important additional insight within the next two or three years.

**Keywords:** Railways; emissions; battery; hydrogen; short-term energy storage; flywheel; hydraulic systems; supercapacitor; ultracapacitor.

## CONTENTS

<b>1.</b>	<b>Introduction</b>	page 3
<b>2.</b>	<b>Battery technology for transport applications</b>	4
<b>3.</b>	<b>Hydrogen fuel-cell technology for transport applications</b>	9
<b>4.</b>	<b>Regenerative braking and short-term energy storage system technology</b>	10
	a) Flywheel energy storage systems	12
	b) Hydraulic energy storage systems	12
	c) Electrical energy storage systems using supercapacitors	12
<b>5.</b>	<b>Traction motors and powertrain configurations for hybrid vehicles</b>	13
	5.1 Electrical motors and associated power electronic systems	13
	5.2 Hybrid powertrain systems	14
<b>6.</b>	<b>Rail applications</b>	16
	6.1 Rail applications of battery technology	17
	6.2 Rail applications of hydrogen fuel-cell technology	18
	6.3 Rail applications of flywheel energy storage (FES) systems	21
	6.4 Rail applications of hydraulic energy storage systems	22
	6.5 Rail applications of supercapacitors	23
	6.6 Hybrid configurations for rail applications	24
<b>7.</b>	<b>Special issues in light rail and tramway applications</b>	25
<b>8.</b>	<b>Discussion</b>	26
<b>9.</b>	<b>Conclusions</b>	27
	<b>References</b>	28

## 1. Introduction

This report provides a review of some issues mentioned in an earlier report entitled “Powering Future Transport in Scotland” [1]. That report covered many forms of public transport and included discussion of the effects of a large increase in electric vehicles, especially private cars, on the electricity supply infrastructure in Scotland. Some of the material in that earlier report was presented at a seminar meeting of the Scottish Association for Public Transport (SAPT) in Perth on 5<sup>th</sup> April 2019. This new report deals more specifically with rail transport and especially with the possible impact of developments in battery, hydrogen fuel cells and short-term energy storage technologies. The information is particularly relevant to the situation in Scotland where there are important secondary rail routes where low population densities make it unlikely that conventional electrification could become a cost-effective solution. Similar situations exist in some other areas of Europe, such as in parts of the Nordic countries.

Growing concerns about exhaust emissions and their effects in terms of climate change and health issues are leading to a re-examination of priorities in terms of transport modes for the future and to the active pursuit of alternatives to the internal combustion engine for both road and rail transport. For rail applications, electrification based on third-rail or overhead line supplies is recognised as a highly cost-effective alternative to diesel traction for inter-city routes that are intensively used, but many secondary lines and regional routes lack the traffic density to allow a business-case for conventional electrification to be brought forward successfully. For such applications the alternatives to traditional electric or diesel traction include battery-electric, hydrogen power and various forms of hybrid configuration (including systems involving conventional electric traction with a secondary battery or diesel engine for use beyond the limits of the electrified network, various battery-electric and diesel combinations or a hydrogen fuel cell and battery-electric configuration). Hybrid systems, involving combinations of these forms of power, are now being recognised as especially important for future railway and tramway applications.

Another way of improving the efficiency of rail transport and reducing emissions is to make use of energy that would otherwise be dissipated as heat during braking. Regenerative braking systems that allow for this and feed energy back into the electrical supply system are already used on some electrified railways and interest in using short-term energy storage based on mechanical, electrical or hydraulic methods on routes which are not electrified has increased rapidly in recent years. Developments in hydraulic systems, flywheels, new forms of battery and electrical energy storage using “super-capacitors” or “ultracapacitors” are highly relevant. Very important, also, are developments in power electronic systems and associated improvements in control systems technology. The optimisation of powertrain systems to maximise the benefits of short-term energy storage presents significant engineering design challenges. Similar systems engineering issues are encountered in the design of hybrid configurations involving hydrogen fuel-cell and electrical battery combinations. Thus, developments in hydrogen fuel-cell systems and battery storage technology link closely with work on short-term energy storage and it is believed that these topics are best considered together.

The development of alternative sources of power for rail and tramway applications is still a developing field. However, there are strong links with research and development activities for other types of transport application, such as electric cars, buses, freight vehicles and ships. Although the United Kingdom is active in research and development activities and in some

important full-scale trials, there is much information available about practical experience already being accumulated in the practical application of these new technologies on railways, tramways and light rail systems in other parts of the world.

The report summarises developments in some relevant areas of technology and discusses how low-emission motive power could be made available for secondary railway routes within the timescales currently being required by government policies. The first three sections of the report that follow from this introduction deal with developments in battery technology that are considered particularly significant for rail transport (Section 2), developments in hydrogen fuel-cell technology (Section 3), developments in regenerative braking and methods of short-term energy storage (Section 4). Traction motors and the associated powertrain systems for hybrid vehicles involving combinations of conventional, battery electric, hydrogen fuel-cell and short-term energy storage systems are considered in Section 5. Section 6 provides information about rail applications of each of the technologies discussed in the earlier sections and includes discussion of some specific hybrid configurations. Section 7 considers special issues that arise in tramway and other light rail applications, while Section 8 provides some further, more general, discussion. Section 9 presents some overall conclusions.

## **2. Battery technology for transport applications**

In the context of electric vehicle applications of all kinds, a battery or **battery pack** should be thought of as a collection of cells within an associated housing, complete with internal and external electrical connections, and also any electronic circuitry needed for control and protection. Each cell within the battery is an electro-chemical unit involving electrodes, an electrolyte and some form of separator. The most common battery types used in modern electric vehicles are **Lithium-ion batteries** or the **Lithium polymer batteries, which are similar in some respects**. Within the cells of such batteries **lithium ions** move from a negative **electrode** (usually graphite) to a positive electrode during discharge and back when charging. The positive electrode is generally made of one of three types of material: a layered **oxide** (e.g. **lithium cobalt oxide**), a **polyanion** (e.g. **lithium iron phosphate**) or a **spinel** (e.g. **lithium manganese oxide**). The electrolyte is usually based on organic carbonates containing lithium ions. Although costs of Lithium-ion batteries are still high, their widespread use and improvements in manufacturing processes are steadily leading to cost reductions compared with other technologies such as Nickel-Cadmium (Ni-Cd) and Nickel-Metal Hydride (Ni-MH) batteries. This is, in part, because Lithium-ion batteries have high cell voltages, high energy densities, long shelf life and good cycle life, and partly because they have fewer environmental issues associated with their manufacture and disposal. A useful review of battery developments relevant to railway applications may be found in the paper by Ghavihaa et al. [2].

One important issue is that the production of batteries currently used in transport applications makes use of materials, such as natural graphite, lithium, nickel, cobalt, manganese and copper. Some of these metals are in scarce supply. Cobalt, in particular, involves some worrying uncertainties [3]. Cobalt is important in lithium-ion batteries as it is a key ingredient that enhances cell stability and thus the safety of the battery pack. This is believed to be particularly important for batteries that are exposed to deep discharge and re-charging cycles, as can occur in transport applications. Worldwide demand for cobalt is growing rapidly and its use in batteries is expected to increase four-fold by 2030, compared with today's figures. More than 64% of the world's mined cobalt is currently extracted in the Democratic Republic of Congo while China is, at present, the world's leading producer of refined cobalt, with 60% of the total refined output coming from there in 2018. International prices of this metal are therefore very

dependent on political stability in this central African country and on trading relationships with China. In addition to mined cobalt there are some low-concentration sources of cobalt which arise mainly as a by-product of copper and nickel mining, but it is not clear how the cost of cobalt refined from these low-concentration sources compares with the cobalt refined from the output of mines where cobalt is the main product. It is also not clear what the carbon costs are for refining of cobalt from low-concentration sources. Other metal supplies that come mainly from one or two sources include manganese (where South Africa produces 20%), nickel (China producing 31%), natural graphite (China producing 69%) and lithium (of which Chile produces 36% and also has most of the world's lithium refining facilities) [3]. New mining sites for minerals used in batteries are constantly being investigated. However, although new sources are being found for some of these critically important metals, it is not clear yet how much this will reduce world dependence on a few key countries. Some of the materials that are important for battery production are also important in modern forms of electric motor which make potential shortages even more significant. It is also important to note that, currently, there appears to be very little recycling from life-expired batteries, but recycling activities are expected to increase.

There is a clear need for all involved in applications of modern battery technology to understand more fully the dependence of battery technology on future availability and the likely costs of key materials. An understanding of research and development activities under way at present is also important as battery technology is evolving and information about new battery chemistries is appearing in scientific and engineering publications at an increasing rate. One approach already being followed involves efforts to reduce the quantity of cobalt used in batteries by a significant factor by using increased amounts of nickel. There is also much research on entirely new forms of battery based on different materials, such as work recently reported at the University of Louvain in Belgium using solid electrolytes instead of the liquid or polymer gel electrolytes found in lithium-ion or lithium polymer batteries (e.g. [4]).

The choice of battery type for a specific transport application depends on many different factors but the most important of these are the energy density (kWh/kg) (a measure of the energy (kWh) that can be stored per kg mass of the battery) and the power density (which is a measure (kW/kg) of the power that can be delivered for a given battery mass). The total mass of the battery and the associated hardware is especially important since lighter batteries reduce the weight of the vehicle and improve its performance.

In considering the suitability of battery power for propulsion of a rail vehicle it is important to note that typical rail applications not only require high energy density to provide an adequate range but also must offer an acceptable level of power-density in order to deal with transient peaks during starting and when ascending steep gradients. In addition, the battery must provide energy for ancillary services such as vehicle lighting and heating. As discussed by Mallinson [5], it must also be recognised that buses, trams and trains have a typical daily operation time of the order of 16 hours, as compared with a typical one-hour average daily usage time for a private car. Batteries for rail applications thus present a demanding set of requirements and, in addition, must be capable of being charged rapidly as well as being durable, safe and offering adequate longevity.

Figure 1 is an idealised schematic diagram of a lithium-ion battery showing the main components. These are the positive and negative electrodes and the electrolyte. In many cases the negative electrode of a lithium-ion cell (where a **reduction process** takes place during the discharge part of the charging and discharging cycle) is composed of **carbon (usually graphite)**. The positive electrode, where oxidation occurs during discharge, involves a

metal oxide (e.g. lithium cobalt oxide), a polyanion (e.g. lithium iron phosphate) or a spinel (such as lithium manganese oxide). Layered structures are normally used within the electrodes. The electrolyte is a lithium salt in an organic solvent. During discharge, lithium ions move from the negative to the positive electrode, through the non-aqueous electrolyte and separator diaphragm, while electrons move through the external electrical pathway. The electrochemical roles of the electrodes reverse during the charging part of the cycle.

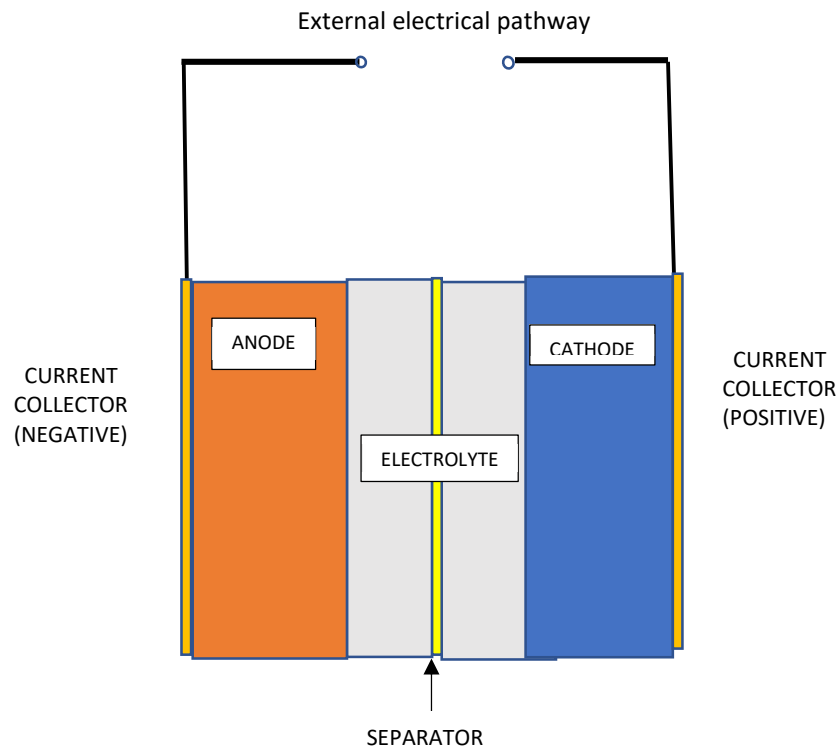

Figure 1: Schematic diagram of Li-ion battery

In the charging phase of the cycle, an external electrical power source applies a voltage which is higher than the normal battery voltage across the electrodes and forces a charging current to flow. That current flow is in the direction opposite to that of the discharge current under normal conditions. The lithium ions then move from the positive to the negative electrode, where they become embedded in the porous material in a process known as **intercalation**. Under normal operating conditions, energy losses from electrical **contact resistance** at interfaces between **electrode** layers and at contacts with current-collectors can be as much as 20% of the entire energy flow of a battery, under typical operating conditions.

New developments which appear to meet many of the requirements for rail applications involve a specific new form of lithium-ion battery based on lithium titanate cells. Such batteries appear to offer good power and energy density characteristics and minimal degradation of performance over many thousands of charge and discharge cycles [6]. Although lithium titanate cells are currently more expensive than other forms of lithium-ion cell, they also appear to offer benefits in terms of safety as they are less prone to thermal problems that can lead to fires or explosions. There are also developments taking place with some related forms of battery which show promise but have not yet been fully tested and evaluated for transport applications. These include other forms of lithium-metal batteries and lithium-sulphur batteries which have properties that could show benefits when compared with currently available lithium-ion batteries, especially in terms of capacity and charge time (see, e.g. [6]). One particularly

interesting development for transport applications concerns “structural batteries” in which the structure of the vehicle is used to form a large battery (see, e.g. [7]). This involves the use of carbon fibre technology, which is already being used in aircraft, in road vehicles and in at least one design of rail vehicle that is entering commercial service.

It should be noted that in 2010 lithium-ion battery prices were around \$US 750-1000/kWh with energy densities of around 110 Wh/kg. By 2018, these prices had fallen by about a factor of four, while densities had increased by more than a factor of two. These cost and energy density trends are already having important effects in terms of passenger and freight road vehicles and is encouraging the development of urban buses and heavy-duty trucks incorporating battery power. China has taken especially important steps in terms of electrification of urban bus fleets, notably in Shenzhen, where the entire city bus fleet (involving over 16000 vehicles) has been converted to battery electric power. In Europe several traditional truck manufacturers have also been making announcements recently about entry into the battery-electric vehicle market [8]. For example, in the early part of 2018 both MAN and Mercedes placed prototype battery-electric trucks into service with customers. Volvo and Renault announced that they hoped to be selling electric trucks before the end of 2019, with a maximum range of 300 km being claimed by Volvo. VDL has partnered with MAN to develop a 37 tonne truck intended mainly for local deliveries, with a range of 100 km. Long-haul applications of battery technology are much more challenging and tend to produce designs involving battery weights that are a significant percentage of the total vehicle weight and more complex hybrid configurations are therefore being considered. For example, Nikola Motors has announced the development of a battery-electric truck with a hydrogen fuel cell range extender. All these developments have important implications for railway applications.

Battery power for rail freight locomotives is not yet well-established and there appears to be a general acceptance that further electrification of trunk routes for freight traffic is the best way forward. However, it is interesting to note that the paper by Zenith, Møller-Holst. and Thomassen, which was presented at the “Hydrogen Train Workshop”, in Brussels in May 2017 [9], reports on a study carried out for one specific route in northern Norway. That study involved analysis of the costs and benefits of using conventional diesel traction for freight trains, compared with other possibilities including biodiesel, overhead line electrification, or battery and hydrogen-hybrid energy. The results provide a positive argument for the use of hydrogen as an energy source for freight trains on routes where conventional electrification cannot be justified. Battery power was judged to be unattractive due to the additional weight of the batteries needed to allow the locomotives to travel the complete route without the need to recharge. The conclusions reported in the presentation are clearly of relevance for other routes.

An entirely different form of battery is now under development that may prove to be important for transport applications in the long term. This is the “flow battery” which is fundamentally different from conventional types of battery in that energy is stored in the electrolyte rather than in the electrode material [10]. Several different classes of flow cells (batteries) have been developed but all involve two chemical components dissolved in liquids contained within the system, most commonly separated by a membrane. Ion exchange processes (accompanied by flow of electric current) occur through the membrane. The energy capacity of a flow battery is a function of the volume of electrolyte while the available power is a function of the surface area of the **electrodes**. Although a flow battery can be recharged in a conventional way, it is also possible for spent electrolyte to be extracted and new electrolyte added rather like the process for refuelling a hydrogen fuel-cell. This is potentially one of the biggest advantages of flow batteries for transport applications since a vehicle could be almost instantly recharged by



replacing the electrolyte liquid, while simultaneously recovering the spent material for re-energization over a longer period of time.

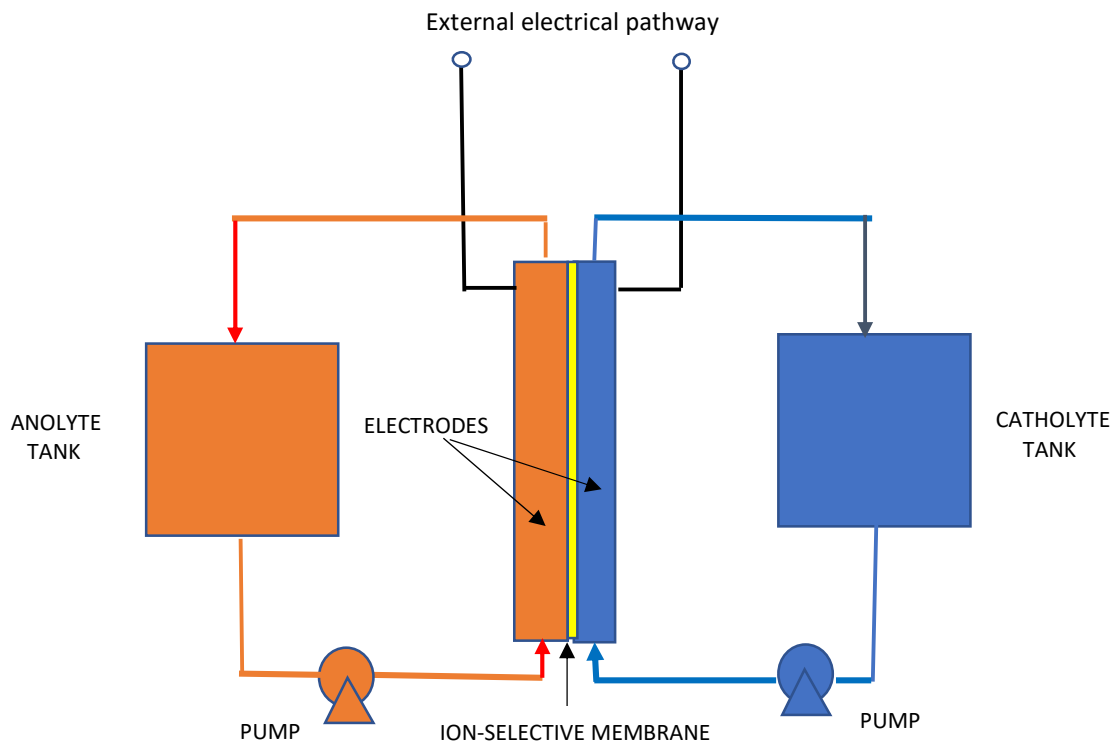

Figure 2: Schematic diagram of a flow battery

Although flow batteries have some attractive features when compared with conventional batteries for static applications, current implementations are less powerful than lithium-ion batteries and require more sophisticated electronics. At the moment they are therefore not seen as competitive with other forms of battery for transport applications, but relevant research is continuing [10]. Membranes are costly and are recognised as being the least reliable components due to problems of corrosion and this has led to recent work on designs that do not include membranes.

Battery technology is advancing rapidly but it is important to note that most forms of battery continue to depend on materials that have some unfortunate properties from an environmental viewpoint and are relatively scarce, as discussed already in the context of cobalt. There are several areas of concern including total energy efficiency, availability of the materials required, battery life expectancy and the environmental effects of mining and processing of materials for modern batteries, as well as end of life disposal issues.

As well as being seen increasingly as an attractive option for private car owners, modern battery technology is now being applied increasingly in buses, especially in urban areas where air pollution is a problem. For example, battery-powered buses have been in use in the central area of Vienna for several years and, in Milan, there are plans to make city-centre public transport entirely electric by 2030 with battery-electric buses as an important element in these proposals [11].



### 3. Hydrogen fuel-cell technology for transport applications

A fuel cell converts **chemical energy** from a fuel such as hydrogen into electricity through an **electrochemical** reaction with oxygen or another **oxidizing agent**. Fuel cells require a continuous source of fuel and oxygen (usually from air) to sustain the chemical reaction. However, unlike batteries, fuel cells cannot be re-charged and will produce electricity only for as long as the supplies of fuel and oxygen are available.

In all types of fuel cell there is an **anode**, a **cathode**, and an **electrolyte**, as show in Figure 2. There is also an external conducting electrical pathway connecting the anode and cathode. A catalyst causes the fuel to undergo an oxidation reaction at the anode which generates positively charged hydrogen ions and electrons. The ions flow from the anode to the cathode through the electrolyte while the electrons are drawn from the anode to the cathode, through the external electrical pathway. At the cathode, another catalyst is involved in a reaction in which hydrogen ions, electrons, and oxygen combine to form water. Several useful and up-to-date reviews of hydrogen fuel cells are available (e.g. [12], [13]). It is clear from comparison of Figures 2 and 3 that fuel cells have some similarities with flow batteries but, as mentioned before, fuel cells are not reversible and cannot therefore be recharged.

Individual fuel cells produce relatively small electrical potentials (about 0.7 V) and cells are therefore usually connected in series, to provide higher voltages or in parallel for high current applications at low voltage. In general, the voltage output of a fuel cell decreases as the load current increases, due to several factors which include activation loss (a fundamental electrochemical phenomenon), internal resistance (analogous to the internal resistance of a battery) and mass transport loss due to depletion of reactants at the anode and cathode under high current conditions. As well as electricity, fuel cells produce water, heat and very small amounts of other emissions. The energy efficiency of a fuel cell is generally between 40–60% but if the waste heat can be usefully applied efficiencies of up to 85% may be achieved. Although hydrogen is generally regarded as a “clean” form of energy this is true only if the hydrogen itself is generated by the electrolysis of water using electricity from renewable sources. Other methods of production are available, such as the extraction of hydrogen from natural gas, but these are not as “clean” as electrolysis from renewables.

The market share for hydrogen fuel cells is relatively small compared with lithium-ion batteries, but hydrogen is already competing directly with batteries for the storage of electricity generated from renewable sources. A key factor that is making hydrogen attractive in this respect is that the energy density of hydrogen already exceeds the energy density for electricity stored in lithium-ion batteries and some have predicted that the energy density of stored hydrogen should exceed the energy density for lithium ion batteries by a factor of ten as early as 2020.

However, hydrogen is flammable and potentially explosive. This introduces additional challenges compared with diesel fuel in terms of vehicle design, in transportation of the gas to refuelling points and in storage. However, vehicles using hydrogen fuel can be refuelled faster than an equivalent battery-powered vehicle.

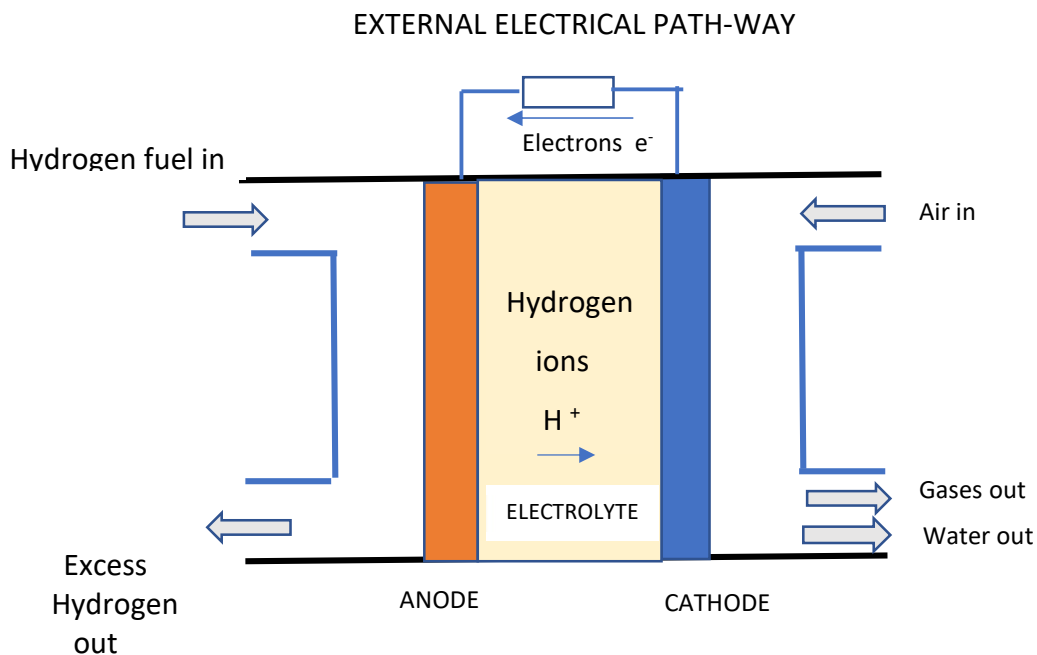

Figure 3: Schematic diagram of hydrogen fuel cell

#### 4. Regenerative braking and short-term energy storage system technology

Recovery of braking energy, in all forms of transport, could help to reduce energy usage and emissions. In electrical transport systems, traction motors can act as generators to convert part of the kinetic energy back into electrical energy and thus provide “regenerative” braking. In practice, only part of the braking energy can be recovered due to losses which are both mechanical and electrical and depend on the details of the system under consideration. This is not a new concept and regenerative braking has been a feature of some forms of electrical traction for many years.

In 2010, a study involving collaboration between First ScotRail and technology firm Artemis Intelligent Power showed that between 65% and 73% of a train’s energy is lost through braking and transmission system inefficiencies [14]. Energy produced in this way may be fed back in electrical form to the power grid or stored in some way, leading to a requirement for components that can store energy quickly and release it over longer periods of time and repeat the process on a regular basis with a high cycle rate.

For electrified railway systems based on alternating current supplies, energy can be fed back into the supply grid with little additional investment in terms of equipment on the trains or at the substations. However, this is not the case with electrified railways and tramways that are based on the direct current system. In such cases substations used to supply the vehicles cannot feed energy back into the grid unless they have additional equipment to allow them to reverse the direction of energy flow and this can be costly. On a dc electrified line which does not have reversible distribution stations the regenerated electricity from one train must be used immediately by other trains passing along the same electrified section. This approach is suitable only for very intensively used routes and ideally requires careful coordination of braking and

motoring by different trains. Such optimisation can be achieved, in part, through careful design of the timetable and but success depends on trains or trams running exactly to schedule and rigorous adherence to a timetable can never be guaranteed. Any regenerated energy that cannot be absorbed by other trains or trams in the same electrical section of the route at the same time must be dissipated in special on-board resistors (or “rheostats”, as they were known). Other than being useful for heating of passenger areas of the vehicle this is not helpful in terms of energy saving but is recognised as being a positive development since it reduces wear on brake blocks and thus reduces harmful particulate emissions. There are also significant copper losses in the overhead line or third rail supply systems.

The extent to which regenerative braking is beneficial depends on the pattern of usage of the rail vehicle being considered. The shorter the distance between stops the greater is likely to be the return on investment in the additional hardware that is needed. This suggests that tramway, light rail and metro systems may show the highest return in terms of benefits from the use of short-term energy storage systems for regenerative braking. Gibson [15] has provided an interesting quantitative analysis of tramway energy demands and his figures have been used (with some slight modifications) as a basis for back-of-an-envelope type calculations presented here to assess the possible benefits of regenerative braking. For example, for a tram with a laden weight of 60 tonnes travelling at a steady speed of 50 km/hr (14 m/s) on straight and level track, the tractive force required is approximately 3000 N, giving a power requirement of 42kW at the rail. Adding electrical losses of 10% this suggests a total power demand of about 46kW (61A for a nominal dc supply voltage of 750V). For modern trams, a typical value for acceleration is  $1.3 \text{ m/s}^2$  so the time to reach a speed of 14 m/s from rest is approximately 11s. For convenience, the maximum braking rate is also taken to be  $1.3 \text{ m/s}^2$  in these calculations giving a braking time from 50km/hr to rest of 11 s. An approximate calculation suggests a tractive force of 81kN is needed to achieve this change of speed in the given time, which (as shown by Gibson [15]), is 27 times greater than the tractive force needed to maintain the steady state speed of 50 km/hr. The power increases linearly from zero when the vehicle is stationary to a maximum of 1.13 MW just before the start of the steady 50km/hr running (corresponding to a current of 1507 A). The kinetic energy at this speed is approximately 5.9 MJ and this can either be recovered as stored energy or will be dissipated as heat. This means that the maximum power available from stored energy is approximately 0.85 MW, corresponding to a maximum current of 1133 A. Allowing for copper losses in the motors and losses in the inverters etc. it is likely that, at best, only about 75 % of the energy is available for re-use and, in practice, the figure may be significantly lower.

One important point that is obvious immediately from this type of analysis is that smaller energy losses in the motors and in the overhead lines or third rail supply are possible if the peak current values can be reduced. Modern motors are becoming more efficient and lighter, as discussed in Section 5.1. This not only reduces internal motor losses but also tends to reduce current values. Finding some way of storing energy on board the vehicle (or in some cases in appropriate trackside storage devices) also allows energy accumulated during braking phases to be usefully applied during a subsequent acceleration phase, without the need to return it to the supply and thus without the associated copper losses. Such on-board storage also reduces the peak current demanded from the supply and thus produces a significant overall increase in efficiency.

Short-term energy storage and recovery of braking energy is relatively straightforward for electrified railway and tramway systems where batteries (or another form of electrical storage device known as a supercapacitor may be used) but, for non-electrified transport systems other

approaches must be found. These include mechanical methods based on flywheels or hydraulic systems.

#### **a) Flywheel energy storage systems**

In flywheel storage systems energy is stored in the form of kinetic energy in a rotating mass. In some modern systems of this kind the rotors are made of high strength carbon-fibre composites, suspended by magnetic bearings, and spinning at speeds from 20,000 revolutions per minute (rpm) to over 50,000 rpm in a vacuum and can reach full speed in a matter of minutes. When energy is extracted from the system, the angular velocity falls and energy added to the system results in a speed increase. Modern flywheel systems have been shown to be capable of reaching their full energy capacity much more quickly than some other forms of storage. Many mechanical regenerative braking systems in use today use electricity to accelerate and decelerate the flywheel but interesting progress is also being made with flywheel systems involving hydraulic power [16].

#### **b) Hydraulic energy storage systems**

The possible use of controlled hydraulic power to store energy in flywheels was mentioned in the previous section. One leading company in this field, Artemis Intelligent Power, was started in the 1990s at the University of Edinburgh (following a “technology licensing” business model). In 2018, Danfoss Power Solutions took a majority stake in Artemis and the company’s Digital Displacement<sup>®</sup> pump technology has been central to recent projects [14], [16]-[18]. This involves a piston-based pump/motor with fast-acting mechatronic valves controlled by an embedded computer. These valves allow cylinders to be enabled and disabled in a controlled fashion in real time, with individual cylinders being active only when required. The company has been involved in several initiatives in recent years concerning the possible use of this digitally control motor/pump device for transport applications and the relevance for rail vehicles is discussed further in Section 6 of this report.

#### **c) Electrical energy storage systems using supercapacitors**

Supercapacitors (also sometimes known as “ultracapacitors”) have electrical properties that resemble those of conventional capacitors that are used in many electronic circuit applications. They consist of two porous electrodes separated by an ion-permeable membrane and an electrolyte. When the electrodes are polarised by an applied voltage, ions in the electrolyte form electric double layers of opposite polarity. Thus, positively polarised electrodes will have a layer of negative ions at the interface between the electrode and the electrolyte along with a charge-balancing layer of positive ions adsorbing onto the negative layer. The opposite is true for the negatively polarised electrode. Energy is thus being stored within an electrochemical double layer.

In comparison with present-day batteries, the specific power (power output per kg) of supercapacitors is typically 10 to 100 times higher (at about 500–10000 W/kg), but their specific energy is considerably lower (typically only 0.2–5 Wh/kg, compared with typical battery figures of over 100 Wh/kg) [19]. Thus, batteries can store more energy for a given weight and volume, making them more suitable as a primary method of energy storage but for short-term energy storage supercapacitors have a significant advantage in that they can provide high output power levels for short periods of time. Hence, supercapacitors are often used together with other electrical storage devices (e.g. Li-ion batteries) to provide hybrid systems

that offer both high specific power and high specific energy. Supercapacitors can also be charged in a very short time with the number of charge/discharge events being almost unlimited over a typical lifetime of the device. This is estimated to be at least ten years which is about double that of a typical present-day battery. Supercapacitors also show good figures in terms of overall energy efficiency (about 95% compared with an equivalent battery system which is typically 75-90%). While supercapacitors are not a recent development, their practical use has only been reported over the past two decades and their costs remain high compared with batteries, although the difference is becoming smaller. Research and development activities aimed at improving the characteristics of supercapacitors are continuing (see, e.g. [19], [20]).

In 2016 worldwide sales of supercapacitors was reported to be about US\$400M which is significant and growing. This is still small compared with the market for rechargeable batteries which is worth tens of billions of US dollars, but it is likely that costs of supercapacitors will fall significantly as demand increases.

## **5. Traction motors and powertrain configurations for hybrid vehicles**

Electrical drive systems for transport applications depend very much on the type of traction motor being used. In addition to higher efficiency, one significant advantage of electrical transmission systems compared with diesel traction is the fact that there is no need for gear systems to ensure that vehicle and engine speeds are matched. Recent developments in electric motor design cannot be separated from developments in the power electronic systems which are essential for the operation of modern motors. The main requirements in choosing the motor characteristics and the associated power electronic drive technology include high torque density, power density, large speed range including constant torque and constant power operations, high efficiency over a wide speed range, robustness and reliability, together with cost.

### **5.1 Electrical motors and associated power electronic systems**

All types of electrical motor work through interactions between a magnetic field and an electrical current flowing in a conductor to produce a force proportional to the product of the field strength and the current. The commonest type of electric motor currently used in modern railway and tramway systems is the induction motor and, in this form of alternating current (ac) motor, the magnetic field is produced by a current in the stator (the “magnetising” current) while the rotor consists of short-circuited windings. Conventionally, the rotor turns inside the stator (apart from some hub-motor designs where the situation is reversed) and there is a small airgap between these two components. An alternating magnetic field is produced by the stator current and this induces currents in the rotor and thus a turning force (or “torque”). The magnetic field rotates, with the rotor also rotating in the same direction. However, the rotor does not have the same angular velocity as the field and there needs to be a small speed difference (or “slip”) to ensure that the magnetic field cuts the rotor conductors and produces current.

Variable voltage, variable frequency power electronic inverters are an essential component of modern electrical drive systems. These are used to transform direct current supplies into alternating current supplies (or vice-versa) through switching of power electronic devices. They are widely used for transport applications where ac motors must be capable of running over a wide range of speeds. Efficiency values for such inverters are of the order of 98%.

The efficiency of modern three-phase induction motors used for railway applications is roughly of the order of 80 – 90 %, depending on operating conditions. Although other types of motor are now attracting attention, the induction motor is maintaining its position due to its relatively low cost and a proven record in terms of robustness and low maintenance costs.

A second type of motor which is being used increasingly in transport applications is a form of permanent magnet motor which may either be a brush-less direct current (dc) machine or a synchronous ac machine. This type of motor can be incorporated into a wheel to produce significant benefits in terms of weight. Losses are also reduced compared with induction motors and this can be beneficial both in terms of power requirements and energy recovered during braking. Some studies have suggested that losses could be reduced by as much as 7% (e.g. [21] - [23]).

As well as inverters, other power electronic systems known as *dc/dc converters* are used within direct current supplies to alter voltage levels in the same way that transformers are used within alternating current supply systems. A dc/dc converter is particularly important in the case of battery or hydrogen fuel cell power sources as the rated voltages of electrical machines are normally much greater than the battery or fuel-cell output voltages. There are several classes of dc/dc converter and these can be divided broadly into unidirectional converters and bi-directional converters. The simplest type of converter is known as a “buck” converter and this changes a fixed input (dc) voltage into an output that can be varied from zero to a maximum that equals the source voltage. This is not sufficient for applications involving battery and fuel cell powered vehicles where there is a need for what is known as a “boost” converter which can change an input source dc voltage level to an output dc voltage level which is higher than the source voltage. The output to input voltage ratio depends on the duty cycle of electronic switching devices within the converter. A “buck/boost” converter combines the buck and the boost converter features, with the output depending on the on the on-off duty cycle of the electronic switching devices. For duty cycles of less than 0.5 the converter acts as buck converter and for duty cycles 0.5 to 1 it acts as boost converter. As with inverters, the efficiency of a dc/dc converter is high (typically 95%) (see, e.g., [24], [25]).

## 5.2 Hybrid powertrain systems

Hybrid vehicles can involve one primary power source together with one or more secondary power source and many combinations are possible. One common configuration involves the use of a conventional overhead electrical power supply (as in railways, tramways and trolley-bus systems) or a third-rail supply (as in many dc electrified railway systems), together with a diesel engine and electrical generator system as a secondary power unit supplying the traction motors when the vehicle is operating away from the electrified network. Similarly, a diesel-electric power unit could be used to provide the primary power with batteries as a secondary source. The benefit of that specific configuration is that battery power can be used in areas where atmospheric pollution presents difficulties, while diesel power is used when operating elsewhere. Another form of dual-power hybrid system that is seen as attractive for some types of application involves a combination of lithium-ion batteries and supercapacitors. This provides the benefits of low vehicle emissions with the rapid charging and controlled discharge of supercapacitors. The high specific energy of batteries and the high specific power of supercapacitors means that these devices offer distinctly different design options for powertrain systems and there can be advantages in using them together. In addition, compared with a battery-only solution, the long life and stress-reduction advantages of supercapacitors can be significant.

The losses in conventional electrification systems include losses in transmission through the third rail or overhead supply. In such systems overall losses are traditionally accounted for using a “generation rate” variable for which a typical value might be 0.85. This means that 15% of power is lost and 85% reaches the traction motors. A similar “regeneration rate” is used to account for losses when regeneration occurs [22].

Fuel cells have dynamic characteristics that involve significant time constants and therefore cannot respond effectively to a rapid demanded change of power output. In hybrid systems there may therefore be advantages in using them in conjunction with other devices for short-term energy storage. For example, a battery pack could be used to supplement the fuel-cell output in situations where there is a rapid change in demanded power for a relatively short period of time, as might occur in starting a train from rest. Short duration events of that kind, requiring high transient power levels could be experienced many thousands of times throughout the life of a vehicle.

Although dual-power systems, such as those mentioned above, are currently the commonest form of hybrid system there is a rapid growth of interest in systems that involve more than two power sources. For example, hydrogen fuel cells, which have dynamic characteristics that are sluggish, may be used together with batteries and a short-term energy storage device such as a flywheel or supercapacitor system to provide a more rapid response to a sudden change of demanded power and also allow regenerative braking within more complex hybrid powertrain configurations.

There has been some significant progress in the development of prototype heavy-road vehicles involving combinations of hydrogen fuel-cells and battery power and the use of supercapacitors in road vehicles has also been receiving attention. Experience with the use of hybrid vehicle powertrain configurations in heavy road vehicles, such as trucks and buses, has undoubtedly been useful in recent developments for the railway and light rail sectors where the market is smaller and where progress has therefore been less rapid. This is true also of developments in the power electronic sub-systems such as inverters and dc/dc converters and in the development of suitable electric motors.

Figure 4 is a block diagram of a typical hybrid system configuration involving hydrogen fuel cells, batteries and supercapacitors. The system, which could relate to a road vehicle as well as to rail vehicles, has an inverter to provide the variable frequency variable voltage supply for the electric motor (typically a three-phase induction motor). It also has three dc/dc converters, two of which are bi-directional. The dc/dc converter coupled between the fuel cell and the dc bus is unidirectional because (unlike batteries or supercapacitors) fuel cells cannot be charged by a reversal of the direction of current flow. During regeneration, power flows from the traction motors back through the inverter system and through the bidirectional dc/dc converters to the battery and supercapacitor. Not shown in this block diagram are the electronic subsystems associated with the overall control and energy management functions that are essential for a complex hybrid system of this kind.



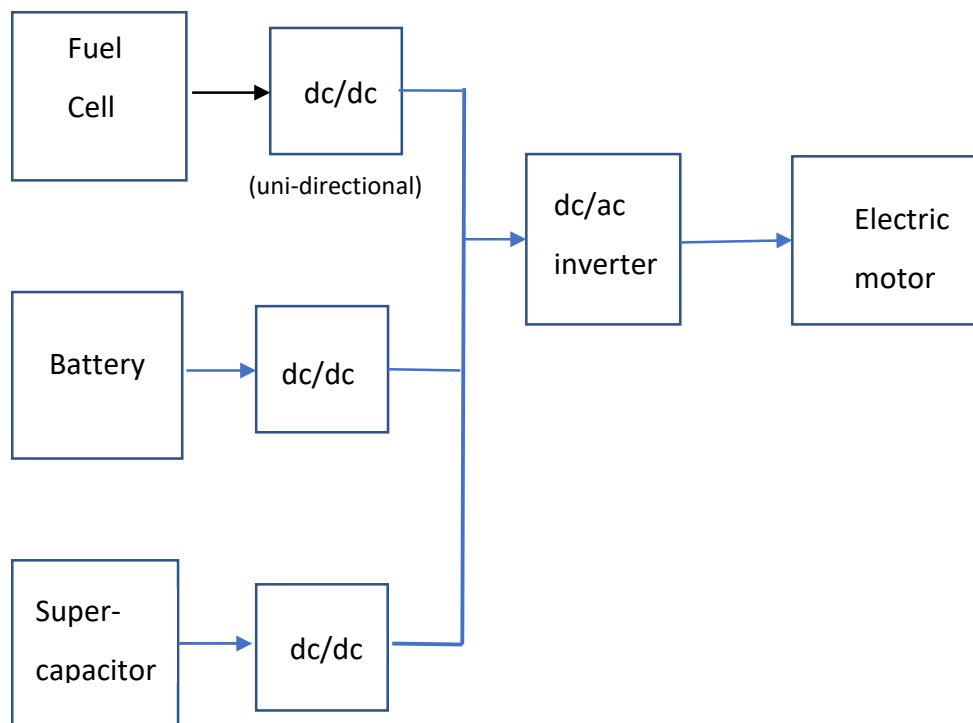

Figure 4: Block diagram of a hybrid system with fuel cells, battery and supercapacitor coupled to an electric motor.

## 6. Rail applications

Although many present-day rail applications of battery, fuel-cell and short-term energy storage technology involve hybrid systems, it is important to consider the advantages and disadvantages of each type of power source for rail applications. Therefore, this section provides a summary of some practical rail applications of each form of technology and some of the issues that can arise in each case for battery technology (Section 6.1), fuel-cell technology (Section 6.2), flywheel energy storage (Section 6.3), hydraulic energy storage (Section 6.4) and supercapacitor devices (Section 6.5). Section 6.6 then provides an outline of rail applications of some hybrid configurations and the issues associated with powertrain design and system optimisation that can arise in such cases.

It is very important in considering the characteristics of a vehicle being designed for a specific task to define a typical duty cycle which will involve phases of acceleration, phases of steady state running and phases of operation where the vehicle is required to slow down and stop. Optimisation of the on-board systems needed to provide the necessary tractive effort is only possible if the planned typical usage is defined carefully from the outset of the design process. The design of the associated systems on the ground, such as catenary or third-rail electrical supplies, and the locations of battery-charging facilities and hydrogen refuelling stations also depend on the planned usage of the vehicle. Costs of providing and maintaining these ground-based facilities are an additional important factor when comparisons are made of different vehicle configurations and power sources.

## 6.1 Rail applications of battery technology

The development of batteries suitable for rail traction applications has close links with the development of batteries for other types of application. Experience currently being gained with the use of battery power in heavy road vehicles such as buses and trucks is particularly relevant.

The use of electrical storage batteries as an on-board power source for rail vehicles became well-established in the 1950s and 1960s in Germany when battery-electric railcars were being quite widely used on some secondary lines. In the UK at that time the most significant development was the introduction in 1958 of an experimental battery-electric multiple unit (BEMU) on the Deeside line between Aberdeen and Ballater [26]. This was the result of a collaborative design and development project involving the Scottish Region of British Railways, the North of Scotland Hydro-Electric Board, Bruce Peebles Ltd and Exide Batteries. As in all railway applications at that time, the batteries used were of the lead-acid type. With a low power to weight ratio such batteries were not ideally suited to the application but the BEMU performed well and the experience gained through day-to-day operation on this 43 mile long branch line, which included some short sections with significant gradients, suggested that battery power could become a serious contender for passenger operations on secondary routes. As in any development project, some problems were encountered. There were some long periods when the unit was out of action and required attention in the workshops, in at least one case due to a fire. The line to Ballater closed in 1965 and the BEMU was not used in revenue earning service after that time. It was transferred to the Railway Technical Centre at Derby where it became a test vehicle used in signalling and train control projects.

Little further thought appears to have been given, in the UK, to battery-electric traction until about 2015 when trials took place of a battery-powered passenger train [27]. Travelling between Harwich International and Manningtree, with the words 'Batteries Included' displayed prominently on the side, the unit involved was a standard Class 379 Electrostar set leased from Abellio Greater Anglia. The project was funded by Network Rail (NR) and the unit was modified by Bombardier to operate either from 25kV ac overhead lines or from the batteries. The target was to operate the 185 ton four-car unit on battery power at speeds up to 120 km/h for distances of up to 50 km. This required a battery capacity of the order of 500 kWh. Lithium-ion batteries were used and charging was carried out using the existing on-board line converter equipment.

The experience gained by Network Rail and Bombardier was clearly useful and Bombardier has since received orders for battery-electric units for use in Germany. In the UK, in October 2018, Vivarail successfully demonstrated its battery powered Class 230 unit on the Bo'ness and Kinneil Railway. It has also been announced that Vivarail will supply diesel-battery hybrid units for use by Keolis-Amey for the Wales and Borders franchise. On these hybrid sets GPS information will be used to cut out the diesel engines in stations and other environmentally sensitive locations. Trials using a Class 230 battery hybrid multiple unit between Evesham and Moreton-in-the-Marsh have taken place. This involves two battery driving motor cars with the addition of an intermediate car housing the diesel generator. The batteries are the primary traction source but are charged by the generator set and through regenerative braking. Five such trains are being delivered for use on the Wrexham to Bidston line [28].

Other recent announcements by manufacturer and vehicle leasing companies include a statement that some Class 319s EMUs are currently being rebuilt by Brush to include battery technology. A leasing company (Porterbrook) has also announced that Class 455 4-car EMUs

could be rebuilt with battery packs to allow use on non-electrified routes and that design work is being undertaken to convert Siemens Class 350/2 EMUs into “BatteryFLEX” trains capable of working away from 25kV overhead routes [29]. Hitachi has also published a proposal for the addition of batteries to Class 385 units to allow their use to destinations currently beyond the electrified network in Scotland (e.g. lines from Dunblane to Perth, Glasgow to East Kilbride etc.) [30].

In July 2018, Bombardier and the Austrian Federal Railways (ÖBB) announced that an order had been signed to provide 25 Talent 3 six-coach electrical multiple units for regional rail services. These units, which are due for delivery in the second half of 2019, have a battery system that can be charged using the overhead wires on electrified tracks or at charging stations on non-electrified routes. The order includes an option for 5 more trains and was based on a framework agreement dating from 2016 [31].

The specification for new trains for the Tyne and Wear Metro includes a “battery boost” feature that is intended to allow a train that has encountered a power failure to move forward to the next station. It is hoped that the first of 84 trains will be delivered in 2021 [32]. A similar system is proposed for the city of Timișoara in Romania where Turkish rolling stock manufacturer Bozankaya is providing 16 five-section trams. These vehicles are intended to be capable of running on battery power for 60km in the event of supply failure.

Many examples can be found of tramway systems with hybrid vehicles that use batteries for some sections of their routes, such as on some modern tramway and light rapid transit systems in the USA (e.g. Oklahoma City and Milwaukee) and in some European cities, where concerns about the introduction of catenary in historic areas have led to designs involving a mix of conventional catenary and battery power. For example, it was announced in October 2019 that the Spanish firm Construcciones y Auxiliar de Ferrocarriles (CAF) has secured a contract from the West Midlands Combined Authority (WMCA) to supply 21 Urbos trams for the Birmingham area in England. These can use batteries to allow them to run on catenary-free sections and CAF also began retrofitting of the existing fleet with lithium-ion batteries in 2018 [33]. An Urbos 3 tram was tested on battery power in Birmingham city centre on August 30<sup>th</sup> 2019 and proved the use of battery power on a steeply graded section of route [34].

A project to treble the existing network in Nice (France) involves Citadis X05 trams operating on two new routes without overhead supplies. These trams are equipped with batteries providing 13.5 kWh of storage capacity and are expected to be in service from December 2019. Their batteries will be topped up at stops in 20 seconds using special Citadis Ecopack ground-based rapid charging systems. Regenerative braking also allows these trams to re-use about 30% of the energy supplied [35]. In a few other cases, such as the new tramway in Doha (Qatar), which was opened in 2018 and a demonstrator line in Busan (South Korea), the systems are based on battery-electric traction only, without any conventional catenary.

## **6.2 Rail applications of hydrogen fuel-cell technology**

Hydrogen fuel cell technology is now being regarded as a promising approach for many transport applications and has made major advances in recent years. Trials with buses are under way in several cities, including some in the United Kingdom.

The use of hydrogen fuel cells for rail applications is not a new idea but it is interesting to note that an up-to-date report, entitled *The Future for Hydrogen Trains in the UK*, was published by

the Institution of Mechanical Engineers in February 2019 [36]. This builds on earlier studies (e.g. [37]) and states that the current overall efficiency of a hydrogen train is about a third that of a conventional electric train. This because hydrogen traction requires 3 kW of electricity to deliver 1 kW of power to the wheel while a conventional electric train needs 1.2 kW. A further problem is that the low energy density of compressed hydrogen means that a fuel tank is needed that is eight times the size of a diesel tank for the same range. The report suggests that hydrogen power should be considered mainly for parts of the country where hydrogen production already occurs (e.g. from renewable energy sources) and where there are opportunities to support integrated rail, bus and electrical power systems using this fuel. Thus, hydrogen might be best used in more remote areas with electricity supplies that are based, mainly, on inexpensive renewables and where there are also poor transmission links to the remainder of the national grid.

It has been suggested that this could lead to the creation of ‘clusters’ of hydrogen-related businesses where the gas is produced and could, perhaps, help local train and bus operators to decarbonise by sharing the fuel distribution costs. As mentioned in Section 2, a recent study in Norway concluded that the business case for conventional electrification of the single-track Trondheim-Bodø line in north Norway was poor and that hybrid hydrogen fuel-cell and battery locomotives might be a better option [9].

Design issues for hydrogen powered trains are also discussed in a 2016 paper by Hoffrichter, Hillmansen and Roberts [38], which also provides some comparisons in terms of energy costs for diesel trains with two possible traction options involving hydrogen. In one of these the hydrogen fuel cell is the primary source of energy, but this charges the battery which powers the traction motors. This powertrain configuration is an example of the type of hybrid approach discussed in Section 5 and is now well-established in prototype systems in several countries.

A report by Kent in 2016 [39] presents some results from a Future Railway Powertrain Challenge project which involves collaboration between the University of Birmingham, Hitachi Rail and Fuel Cell Systems Ltd. The aim of the work is to develop a novel powertrain based on fuel cell technology, suitable for retro-fitment to mid-life diesel multiple unit rolling stock such as the Class 156 DMU, and for fitment to a new generation of regional multiple units, based on a modified version of Hitachi’s AT200 EMU. This is the family of multiple unit designs by Hitachi for regional and outer suburban use and the Class 385 design now being used for services in Scotland is a member of the AT200 family. The 2016 report describes Phase 1 of the Fuel-Cell Electric Multiple Unit (FCEMU) Project, involving a study of the potential for converting these two very different existing designs of multiple unit to hydrogen power. This report is particularly useful in that it provides a quantitative assessment of the potential of hydrogen fuel-cell operation on trains built to the UK loading gauge.

Two configurations were considered. One of these involved using power from the fuel-cells directly with no battery in the powertrain. The second was a hybrid approach with a battery which could be charged up through regenerative braking and from the fuel cell while the unit was in the cruise mode and during dwell times at stations. The second of these options was found to be preferable, both for the Class 156 retrofit and for the AT200.

In the Class 156 study it was found that (on a per vehicle basis) the use of a 250kW traction motor would necessitate use of a fuel cell of approximately 200kW power rating together with a battery pack of about 20kWh storage capacity and 200kW power rating. The hydrogen storage tanks would be pressurised to 350 bar (1 bar being defined as 100 kPa which is slightly

less than the average atmospheric pressure at sea level). This 350 bar pressure for gas tanks is a value widely used in transport applications and is roughly equivalent to a pressure of 5000 lb/sq. inch. The gas storage capacity per vehicle required for a 500-mile operating range on the route considered in the study (in East Anglia) was found to be at least 63kg. The retrofit would involve removal of all existing equipment between the bogies of each coach in order to provide enough room for all the necessary equipment and the hydrogen storage tanks. In the case of the AT200 it was found that space could not be available for all the necessary equipment and storage tanks in a two-coach unit. With four coaches (two powered and two trailer coaches) there was adequate capacity for two 200kWh fuel cells, storage tanks and larger battery packs.

Consideration is given in the report by Kent [39], to how hydrogen can be sourced, and comparisons are made of the electrolysis and reformation approaches. Emissions of oxides of nitrogen and particulates (other than those from brakes) would be almost eliminated whatever method of hydrogen production were used. In terms of carbon emissions, there would be a 100% reduction in carbon if hydrogen were produced by electrolysis using only renewable or nuclear energy. If reformation of natural gas were used, the corresponding carbon emissions reduction would be 43% compared with the Class 156 units with diesel power. On the other hand, if hydrogen were produced by electrolysis using energy from the electrical distribution grid (on the basis of the 2016 average mix of generation methods) there would be a 33% increase in carbon emissions. This shows very clearly that hydrogen is best produced by electrolysis using renewable sources and supports the concept of clusters of hydrogen users in remote areas with various forms of transport and other industries also benefitting. A total of about 2000 kg of hydrogen would be required per day for a fleet of 25 modified Class 156 units. Using natural gas as the source of hydrogen the fuel costs per mile would be reduced by 63%. However, taking costs of train conversion and the installation of the hydrogen production plant into account there would be a long payback period, estimated as being close to twenty years. This is not particularly attractive, but the study concluded that, in the case of the South Wales valley lines, the investment needed for a fleet of the size considered (25 units) would be of about one seventh of the cost of conventional electrification for the routes being considered.

In terms of trains in regular passenger service the prime example is in Lower Saxony in Germany where two Alstom Coradia iLint hydrogen-powered trains are being used on a 50km route [40]. The local government of Lower Saxony has plans for 14 additional trains of this type, to be in service by 2021. The units have a maximum speed of 140km/hr and are said to be less expensive to operate than the equivalent diesel units that they are replacing. Although frequently referred to as “hydrogen trains” the iLint units are (like most other hydrogen-powered trains and heavy road vehicles) actually hybrids, with hydrogen fuel cells as the main power source and excess energy being stored in lithium-ion batteries. A full tank of hydrogen provides these units with a range of about 1,000 km which is enough for a full day of usage without any need for refuelling.

In the United Kingdom, projects announced recently include the Porterbrook ‘HydroFLEX’ demonstration project which will be based on a Class 319 unit. This involves collaboration with the University of Birmingham’s Birmingham Centre for Railway Research and Education (‘BCRRE’) [41]. A hydrogen-powered train for the UK market is also under development by Alstom in collaboration with and the rolling stock leasing company Eversholt Rail. Known as the “Breeze” this vehicle will be based upon an existing Class 321 multiple unit [42].

Vivarail claims to be the first UK manufacturer to offer a hydrogen powered train of proven design [43]. This is a hydrogen/battery-electric version of the diesel/battery-electric Class 230 announced earlier. It has hydrogen fuel cell and hydrogen storage tanks below the floor in an intermediate vehicle instead of the diesel engine and diesel fuel tanks. The unit has a range of 650 miles and incorporates regenerative braking. Since these two types of power unit and storage tanks occupy the same space, the modular approach that has been adopted by Vivarail is claimed to allow easy transition from a diesel/battery to a hydrogen/battery hybrid configuration.

Rail authorities in other countries are also starting to consider investment in hydrogen-powered trains. France, for example, has plans for hydrogen power and other projects are under way in Germany, Austria the UK and China, where in 2015 a hydrogen-powered tram started operation in Qingdao. The TIG/m company, based in California, U.S.A., has built a 3km tramway in Oranjestad, Aruba, with two heritage style hybrid battery/hydrogen powered trams. This predominantly tourist line opened to passengers in February 2013 [44].

Austrian Railways (OBB) has published a tender for a 12 month hire contract for two hydrogen powered multiple units. The company wants to compare these with its battery powered Siemens *Desiro ML* battery powered EMU (OBB *Cityjet eco*). OBB had previously announced that it intended to operate all trains with zero carbon dioxide emissions from 2035 [45].

From December 2022 hydrogen fuel cell operations on passenger services are also planned for the narrow-gauge Zillertalbahn in Austria using new Stadler units [46]. In Germany, the Frankfurt-am-Main regional transport authority rolling stock subsidiary has ordered 27 Alstom 2-car Class 654 iLINT hydrogen fuel cell powered multiple units to be delivered by December 2022. It is particularly interesting to note that the contract includes supply of hydrogen for 25 years [47].

### 6.3 Rail applications of flywheel energy storage (FES) systems

Flywheel systems are in use in some small [electric locomotives](#) intended for shunting e.g. the [Sentinel-Oerlikon “Gyro” Locomotive](#). Some larger electric locomotives have also been designed with flywheels. These include locomotives built by the Southern Railway in 1942 (later designated as BR Class 70 locomotives), and a later design for British Railways in the 1950s (Class 71). Both these types of locomotive were designed for use on routes electrified on the third-rail dc system and used flywheels to ensure that power would not be lost over short sections where there were gaps in the third rail. Such gaps are inevitable with third-rail electrification but do not present problems for electric multiple unit passenger trains which have several pickup shoes at different points along the length of the train.

Flywheel storage systems can also be used at the lineside on electrified railways as static energy storage systems to help regulate the line voltage, thus improving the acceleration of electric trains and this also allows energy to be recovered through [regenerative braking](#). Examples can be found in Japan, dating from about 1970. In South Korea a case study has shown that a section of line with flywheels in seven substations has produced a significant reduction in peak power demand and is said to have given important cost savings.

In terms of more recent developments involving on-board flywheels, one well-known example in the UK is the hybrid Parry People Mover system used in Class 139 railcars which incorporate an liquid petroleum gas engine and a flywheel. These units have operated for some time on the [Stourbridge Town branch line](#) in the [West Midlands of England](#).

A different approach has been taken by technology firm Artemis Intelligent Power in conjunction with Ricardo and Bombardier. These partners have been working since 2013 on a project entitled “Digital Displacement<sup>®</sup> Rail Transmission with Flywheel Energy Storage” which has been supported by the government funding body Innovate UK. This system is intended for use in diesel multiple unit trains and employs Artemis Digital Displacement<sup>®</sup> pump-motors to capture braking energy, store it using Ricardo flywheels and then use it during vehicle acceleration. This is a form of regenerative braking, but the novelty lies in its application to diesel trains with mechanical transmissions. A test rig has been developed. Expected fuel savings are of the order of 10% with a potential return on investment within five years (see e.g., [16] - [19]).

#### **6.4 Rail applications of hydraulic energy storage systems**

As mentioned in Section 4 above, a new design of hydraulic transmission intended to improve the acceleration of diesel multiple-units and reduce fuel consumption has been successfully demonstrated in Scotland under an 18-month programme involving the digital displacement pump/motor system developed by Artemis Intelligent Power. The £1.7m project was part-funded by the UK Rail Safety & Standards Board (RSSB) through its ‘Powertrain’ competition. The project has several other partners including Chiltern Railways, JCB, Centa Transmissions and Hydac and involves use of a Mk III driving van trailer loaned by Chiltern Railways which has overall dimensions and weight close to those of modern UK diesel multiple unit vehicles. The Artemis hydrostatic transmission is based around the digitally controlled radial piston type of hydraulic pump/motor mentioned in Sections 4 and 6.3. The demonstrator vehicle is fitted with two hydraulic pumps powered by standard industrial diesel engines which drive two hydraulic motors on one bogie which are connected to the axles by a final drive. Connections between pumps and motors is through flexible hydraulic lines. One advantage of the hydraulic transmission is that the diesel engine always operates at peak fuel efficiency and reduced energy losses between the engine and the wheels. Energy recovery through regenerative braking is also possible through provision of on-board energy storage through use of high-pressure hydraulic accumulators. Deceleration involves reversing the drive motors so that they act as hydraulic pumps to feed the accumulators. When the stored energy is needed to allow the train to accelerate again the power unit is switched to motoring mode. This means that the diesel engines need not be run in station areas, thus eliminating potentially harmful diesel emissions and Artemis estimates that the system could potentially be used to ensure that the acceleration of diesel-powered vehicles could match that of an electrical multiple-unit (see e.g., [14], [16] - [18]).

The energy storage capabilities and the infinitely controllable transmission system allows operation with diesel engines that are smaller than would normally be installed in a typical diesel multiple unit. The modified driving van trailer used for trials is powered by two standard JCB ecoMAX engines rated at 129 kW, and this is significantly smaller than the 300 kW diesel engines normally used for a typical DMU application. Testing of the experimental unit has included trials on the Bo’ness & Kinneil Railway in central Scotland. This line includes a steeply graded section which allowed testing to be carried out under some demanding conditions. Results from the testing programme suggest that fuel savings of more than 30% may be obtainable. Following the successful completion of the test programme, an industry demonstration day was held in October 2018.



In a separate, but closely related development, Artemis Intelligent Power has been engaged in a project, in conjunction with Abellio ScotRail, to investigate potential benefits that could be obtained from fitting a digital displacement pump unit and flywheel energy storage to the auxiliary drive of a ScotRail Class 170 diesel multiple unit since supplying auxiliaries such as cooling fans and the electrical generator is estimated at present to require about 10-15% of the output of the diesel engines. The project was partly funded by the U.K. Rail Safety and Strategy Board (RSSB) and included testing of a Class 170 unit fitted with a digital displacement pump, on a number of different routes in Scotland. The results suggested that if the same modification was made to the complete fleet of ScotRail Class 170 units (for the units then in use with Abellio Scotrail) the annual CO<sub>2</sub> emissions would be expected to come down by at least 4000 tonnes. The actual savings in terms of diesel fuel would be about 1.5 million litres (see e.g. [14], [16]-[18]).

## **6.5 Rail applications of supercapacitors**

Supercapacitors have several potential advantages over other on-board secondary energy sources. Unlike flywheels and hydraulic systems, they have no moving parts and systems based on these devices are thus likely to require less maintenance effort. Unlike batteries, their high specific power capabilities allow the vehicle to store most of the energy produced by regeneration and their long life-expectancy is another very positive feature. In Europe, practical rail applications of supercapacitors began in 2003 in Mannheim (Germany) when tests were carried out using a prototype light-rail vehicle from Bombardier. Using supercapacitors a power level of 600kW was available in the starting phase of operation and the vehicle could be driven for a distance of up to 1 km without any overhead line supply. It was also claimed that the results showed that this form of onboard energy storage could save up to 30% of total energy costs and could reduce the peak demand by up to 50%. As well as being used on electric trains, supercapacitors have also been used in Germany for short-term energy storage on hybrid diesel-electric multiple units which use diesel generators for an electrical traction system.

Supercapacitors can also be used at the trackside (see, e.g. [48], [49]) in the same way as the lineside flywheels mentioned in Section 6.3. Simulation studies involving on-board storage (see e.g., [50]) and also trackside storage in d.c. electrified systems provide encouraging results in terms of their potential for energy recovery (e.g. [51]) and various lineside and onboard energy storage methods have also been discussed in other papers describing simulation-based investigations (e.g. [52]).

In August 2012 the CSR Zhuzhou Electric Locomotive Corporation of China announced a prototype two-car light metro train equipped with a roof-mounted supercapacitor unit. Information released about this unit suggested that it could travel up to 2 km without wires and could recharge in 30 seconds at stations via a ground mounted pickup. In 2014 seven trams equipped only with supercapacitors were supplied for operation in Guangzhou (China). In this case the supercapacitors could be recharged in 30 seconds by a device positioned between the rails and this could power the tram for up to 4 kilometres. Wuhan has a fleet of 21 CRRC designed four-section supercapacitor trams for the Auto City line, with Siemens traction and braking equipment. These have capacity for 400 passengers and a range of 3 km after each charge which typically takes between 10 and 30 seconds. A second fleet of 26 trams has been supplied by CRRC for the Guanggu Optics Valley lines in the eastern suburbs of Wuhan and these are equipped with on board energy storage for operation without overhead [53]. The possibility of eliminating catenary also means that supercapacitors can be an attractive

proposition for tramway routes that pass through historical city areas and can thus help preserve architectural heritage.

## 6.6 Hybrid configurations for rail applications

As mentioned in Section 5, the simplest forms of hybrid systems for rail applications involve bi-mode arrangements using conventional electrical power from a third rail or catenary supply on electrified sections of a route with a switch to diesel propulsion on non-electrified sections. This applies both to main-line passenger trains (e.g. in some versions of the new Azuma units being introduced on the GWR and LNER franchises in the U.K.) and to freight locomotives which are also appearing in various hybrid forms. These range from electric locomotives equipped with small auxiliary diesel engines for use over short distances when the locomotive is operating beyond the limits of the electrified system (e.g. on some non-electrified sidings) to fully hybrid versions where the locomotive can operate for long distances using either electric or diesel power (e.g. the mixed-traffic Class 88 locomotives built by Stadler Rail and operated by Direct Rail Services the U.K.).

In South Wales a mix of three and four car Stadler Flirt tri-mode units is being ordered. Batteries will allow cross-city services to be provided on non-electrified routes while 25kV traction equipment permits full electric operation where the overhead is provided. It has been stated that full electrification of the routes concerned would be costly as many structures would have to be modified or replaced. In normal operating conditions it is expected that zero-carbon operation will be achieved, but a modern low-emission diesel engine and electrical generator is provided in a middle coach and this will allow charging of the batteries. The diesel engine and generator unit offers extra resilience in the event of power supply problems and it has been stated that the units could easily be modified for hydrogen fuel-cell operation in the future [54].

These relatively simple situations involving a switch over from one form of power to another most often do not involve storage of energy on-board the vehicle. When there is a need for on-board energy storage, such as in a hybrid vehicle involving the use of conventional electrical power for most of a route and battery-electric power to extend its use over non-electrified sections, it is possible to recover energy through regenerative braking. This leads to a more efficient but more complex powertrain configuration. The concept has been applied on modern tramway and light rapid transit systems as well as on urban and mainline railways, as mentioned already in Section 6.1.

Hybrid systems involving hydrogen fuel cells and battery power also allow for regenerative braking. Indeed, as pointed out in Sections 3 and 6.2, the dynamic characteristics of hydrogen fuel cells mean that they do not respond quickly to demanded changes of power level, as would occur in starting a train or during the subsequent acceleration phase. Hence most rail applications of hydrogen fuel cells are hybrid systems that involve batteries. This also allows for some recovery of braking energy as conventional fuel cells are not reversible devices. An interesting new trend in rail applications involves hybrid systems equipped with both batteries and supercapacitors so that the high specific energy of batteries is combined with the high specific power of supercapacitors, thus allowing full advantage to be taken of regeneration. Simulations studies suggest that the use of batteries in combination with supercapacitors has a number of advantages compare with the use of batteries alone. Dynamic stress and heating effects within the batteries due to large transient currents are reduced significantly through the use of supercapacitors and battery voltage fluctuations are also reduced [2].

The use of a hybrid approach that combines batteries and super capacitors allows active sharing of power. Super-capacitors have characteristics that involve a higher power density but a lower energy density than batteries and, as a result, they can provide a high current for a short period of time (typically a few tens of seconds at most). Therefore, in a hybrid system they can reduce the burden on the battery to provide high current, which is not good for the battery health and lifetime. In addition, unlike batteries, super-capacitors allow deep discharges to occur (even from 100% to 0% state of charge) without the risk of long-term damage. Effective use of hybrid systems requires careful optimisation at the design stage to ensure that electric motors, fuel cells, batteries, short-term energy storage devices and power electronic systems all have appropriate characteristics for the intended application.

## **7. Special issues in light rail and tramway applications**

One of the most important factors that distinguishes tramway and light rail system applications is that the distance between stopping points is normally quite short so that the vehicles spend much of their time accelerating and braking. For example, for a tram operating in an urban situation with a maximum speed of 50 km/hr and a distance between stops of 500 m, a typical time for acceleration from rest to a steady-state speed of 50 km/hr on level track is 11 s, as discussed in Section 4. If we assume that there is no coasting phase and that the tram also takes 11 s to stop from the cruising speed, the total distance over which the tram is either accelerating or braking is 154 m and the distance for operation in the cruise mode is therefore 346 m which takes just 24.7 s. at the chosen speed of 50 km/hr. Thus, about 47 % of the journey time between stops on this simplified journey profile involves acceleration or braking. This is very different from most other forms of rail transport where acceleration and braking form a much smaller proportion of the total journey time. This emphasises the fact that tramway, light rail and metro systems, which involve many stops over a relatively short distance, can benefit very significantly from the application of regenerative braking and short-term storage of energy on-board. This not only allows re-use of some energy during acceleration that would otherwise be dissipated as heat but, in cases where conventional electrical supply systems provide the main source of power, it also reduces the peak currents being drawn from the overhead or third rail infrastructure and thus reduces copper losses in the supply system so that overall efficiency levels are increased.

The relatively short distances between stops on most tramway, light rail and metro systems provides another interesting possibility in terms of battery operation using rapid charging facilities at each stopping point. There are obviously several different possibilities for these charging facilities including a short section of catenary or third rail at selected stopping points and a pantograph or pick-up shoe on the vehicle which can be positioned automatically when the vehicle is stationary. Alternatives include energy transfer through wireless induction systems, although such an approach is at present less efficient than the direct contact methods. Clearly the route characteristics and vehicle duty cycle are important factors in determining the positions of these charging points but the overall costs should be significantly lower than the costs of providing continuous overhead catenary systems (which are said to account for about one third of the costs of typical new tramway infrastructure). The provision of larger numbers of charging points at evenly spaced intervals means that on-board batteries can be smaller and thus less costly. With fewer stops batteries tend to have to be larger with longer charging times at termini. Rapid charging does, however, place significant demands on the electrical supply infrastructure [1] and provision of rapid charging systems for tramway and light rail applications are not yet common. However, some applications have been reported from China.

One very recent development is the testing in China of hydrogen fuel-cell trams for the Gaoming line in Foshan, Guangdong province, China [55]. The vehicles are powered by FCveloCity fuel cell modules from the Canadian-based company, Ballard. The trams have a maximum speed of 70 km/hr and a range of 125 km before refuelling is necessary. Passenger services are expected to begin early in 2020.

## 8. Discussion

Reduction of emissions through developments in battery and hydrogen fuel-cell technology has attracted much recent attention in the media, especially in the context of road transport and private car usage. Clearly, railways need to be seen by the public and by politicians as a clean and sustainable modal choice and the drive for more environmentally friendly forms of transport make the choice of future rolling stock for the non-electrified parts of the railway network a potentially sensitive issue.

Any comparisons of battery and fuel-cell technology for transport must focus on key issues such as vehicle performance requirements, total lifetime costs, the infrastructure changes required for battery charging and hydrogen fuel supply and supply chain issues in the manufacture of batteries and fuel cells. To support new developments the Rail Safety and Standards Board (RSSB) in the UK has set up a Decarbonisation Task Force. In April 2019 an award of £1 million to six projects was announced as part of a sustainability initiative involving that Task Force. Several of these projects involve partnerships between university research groups, manufacturing industry, vehicle leasing companies and train operators and most relate directly to topics discussed in this review. For example, one project aims to investigate engineering and commercial aspects of the application of Digital Displacement Technology to non-passenger rail transport. A second is looking at dual-fuel locomotives for freight operations, while another is investigating renewable power in the optimisation of traction energy usage on passenger networks electrified using the 25kV ac system. One further project is dealing with aspects of the production, delivery, compression and storage of hydrogen for railway applications. In another recent development involving university and industry collaboration, the Porterbrook company has leased an HST set to the University of Birmingham for research and development work that includes the investigation of alternative power sources for rail applications with demanding duty cycles such as those arising in long-distance passenger or freight operations [56].

The mention of freight in connection with the research being undertaken at the University of Birmingham, as outlined above, highlights the fact that passenger rail transport has been given most emphasis in this report. This is because it has been assumed that the main arterial routes for rail freight are already electrified or are strong candidates for electrification in the future. The only published study found which includes an assessment of the potential use of batteries or hydrogen fuel-cells as a primary energy source for long-distance freight operations is the Norwegian report referred to in Sections 2 and 6.2 [9]. Other than bi-mode locomotives and conventional electric locomotives with auxiliary diesel engines for operation over “last mile” situations where no catenary exists, there has been little development work on other energy sources for freight. Some combination of electric and diesel motive power seems likely to continue for the foreseeable future (see e.g. [57]). However, energy recovery and short-term energy storage techniques could clearly be applied, with significant benefits, to the freight sector. The current development work being carried out on flywheel and hydraulic systems is potentially important for reduction of emissions and improvement of overall efficiency in

situations where internal combustion engines continue to be used as the main source of motive power.

Clearly, much remains to be done before battery and hydrogen power sources become commonplace in the rail sector and it is important that those working within the rail industry keep themselves fully aware of relevant developments across all forms of transport. For example, experience now being gained in the bus and truck industry with battery-electric power and hydrogen fuel cells is of considerable relevance for rail transport applications. There are also some areas of research in battery, fuel-cell and short-term energy storage technology that require careful monitoring as they may lead to important new opportunities in a relatively short time scale. For example, routine application of hydrogen fuel cell technology is still at an early stage and one of the main reasons for this is the cost of hydrogen. At present, hydrogen gas is usually produced either by a process that gives 'brown' hydrogen made by reforming of fossil fuels using steam and the currently more-expensive 'green' hydrogen produced by electrolysis. However, other methods of production are the subject of research and development projects, some using domestic waste or discarded plastic. Although these have not yet been applied on a commercial scale in this country it is important that progress with developments of that kind be reviewed regularly as they could well lead to important changes in terms of the economics of hydrogen supply.

One other area of research and development that is vitally important when considering hybrid vehicles relates to powertrain design. Complex powertrain configurations, such as those needed for vehicles that use battery power in conjunction with hydrogen fuel cells and supercapacitors usually involve induction motors or permanent-magnet synchronous motors, together with complex power-electronic subsystems such as inverters and dc/dc converters. Rapid developments are taking place in all these areas. Design optimisation of powertrain systems, as mentioned in Section 6 of this report, involves complex decision-making, both in terms of technical issues that may have a bearing both on performance and on capital and maintenance costs. Important benefits of optimisation, based on well-proven computer simulation models of drivetrains, have been demonstrated in other application areas and especially in the automotive industry. The relevance for rail transport is very considerable and, given the longer life of rail vehicles compared with road vehicles of all kinds, opportunities for major lifetime savings through the careful application of optimisation techniques are substantial.

## **9. Conclusions**

There is clearly scope in the United Kingdom for significant additional rail infrastructure improvements and further electrification. Where traffic densities would not justify conventional electrification over a complete route, new possibilities are provided through developments in hybrid rail vehicles using a combination of conventional electrical traction, hydrogen fuel cells and batteries. Developments in energy storage to recover braking energy using electrical, mechanical or hydraulic techniques are also very interesting and appear to have the potential to reduce energy costs significantly on many routes. Some developments of this kind have been shown to be applicable to existing designs of diesel and bi-mode trains and could possibly lead to reductions in energy costs and emissions without having to invest in new trains. A modular approach in which power units can be interchanged relatively easily, which has been adopted by at least one manufacturer, is also of considerable interest as it could reduce the risks of obsolescence as new developments appear in terms of batteries, fuel cells, short-term energy storage systems and powertrains.

The automotive sector is already carrying out development work and supporting longer-term research in areas such as electrical batteries, fuel cells and improved designs of electric motor. Although some of those developments are likely to be of value to the rail industry, especially in connection with heavy electric road vehicles (see e.g., [6]), it is important that rail transport requirements should be brought more to the forefront of developments in electric motor design, power electronic systems, fuel cell systems and energy storage. Problems associated with the integration of such systems to maximise performance and economy in both rail passenger and rail freight applications should become a priority. Without this, the specialist requirements of railways and tramways are likely to be neglected and innovative solutions that might lead to more affordable and sustainable transport by rail could be neglected.

Given current targets in terms of carbon and other emissions that are harmful to health, conventional electrification of most of the existing rail network is being recognised increasingly as the best way forward. Although conventional railway electrification should clearly form a major part of the strategy, further development of less conventional power sources and short-term energy storage systems are also recognised as important. Special attention should be given to the problems of control, management and overall optimisation of the complex power electronic systems associated with different power sources and energy storage devices. There is considerable scope for improvement within that area of technology, with significant cost and performance benefits being possible.

External factors, such as the availability of the raw materials for battery and fuel-cell manufacture (and the closely associated questions of likely future costs) also need to be kept under close review. This is a rapidly changing area of technology and political pressures in terms of emissions targets must be weighed carefully against practical issues when decisions are being made about potential solutions. Careful consideration must also be given to total lifetime costs from mining and manufacture through to final disposal or recycling, both in financial terms and in the context of carbon and other harmful emissions.

**Footnote.** This review forms part of a more extensive study concerned with public transport energy costs and emissions in the specific context of future power sources for transport in Scotland. It provides preliminary results from an ongoing study that was started in May 2018. Links shown in the reference list were successfully accessed during October and November 2019, but the availability of the relevant on-line sources cannot be guaranteed. The author wishes to acknowledge support and assistance from members of the Scottish Association for Public Transport (SAPT) who have provided useful information about reports and articles of direct importance for this review.

## References

- [1] Murray-Smith, D. (2019). *Powering Future Transport in Scotland*. A report for the Scottish Association for Public Transport, June 2019. <http://eprints.gla.ac.uk/189828/1/189828.pdf>
- [2] Ghavihaa, N., Campilloa, J., Bohlinb, M. and Dahlquist, E. (2017), Review of application of energy storage devices in railway transportation. *Energy Procedia* 105, 4561 – 4568. <https://reader.elsevier.com/reader/sd/pii/S1876610217310950?token=111C7C75FC66A169CA9760A5D80756E384D656670F1C65CB407BC63BFF8B751842C316B15EB1BEE02ABC29471AB3A397>
- [3] Anonymous (2018). *Report on Raw Materials for Battery Applications*. EU Commission, Staff Working Document, SWD(2018) 245/2 final, 22nd November 2018. <https://ec.europa.eu/transport/sites/transport/files/swd20180245>
- [4] Anonymous (2019), A new material for the battery of the future, *Science Daily*, July 17 2019. <https://www.sciencedaily.com/releases/2019/07>

- [5] Mallinson, N., (2018), Better connected, *Tramways and Urban Transit*, No. 963 (March 2018): 100-101.
- [6] Eftekhan, A. (2017). Energy efficiency: a critically important but neglected factor in battery research, *Sustainable Energy and Fuels*, 1: 2053-2060.  
<https://pubs.rsc.org/en/content/articlelanding/2017/se/c7se00350a#!divAbstract>
- [7] Loughran, J. (2018). Carbon fibre vehicle chassis shown to store energy like a battery, *Engineering & Technology*, 13 (11/12), December 2018/January 2019: 9  
<https://eandt.theiet.org/content/articles/2018/10/carbon-fibre-vehicle-chassis-shown-to-store-energy-like-a-battery/>
- [8] Earl, T., Mathieu, L., Cornelis, Samuel Kenny, Ambel, C.C. and Nix, J. (2018). Analysis of long haul battery electric trucks in EU: Marketplace and technology, economic, environmental, and policy perspectives. *Proceedings 8th Commercial Vehicle Workshop, Graz, 17-18 May 2018* <https://www.transportenvironment.org/sites/files/publications/20180...>
- [9] Zenith, F., Møller-Holst, S. and Thomassen, M. (2017). *Alternative railway electrification in Norway*, Paper presented at FCH 2JU & S2R JU “Hydrogen Train Workshop”, Brussels May 15 2017. <https://www.sintef.no/en/projects/hydrail/>  
 and also:  
[https://www.fch.europa.eu/sites/default/files/default\\_images/10.%20SINTEF\\_Norway%20case%20%28ID%202902217%29.pdf](https://www.fch.europa.eu/sites/default/files/default_images/10.%20SINTEF_Norway%20case%20%28ID%202902217%29.pdf)
- [10] Anonymous (2018), Science for Environment Policy, *Towards the battery of the future*. Future Brief 20. Brief produced for the European Commission DG Environment by the Science Communication Unit, UWE, Bristol.  
[https://ec.europa.eu/environment/integration/research/newsalert/pdf/towards\\_the\\_battery\\_of\\_the\\_future\\_FB20\\_en.pdf](https://ec.europa.eu/environment/integration/research/newsalert/pdf/towards_the_battery_of_the_future_FB20_en.pdf)
- [11] Anonymous (2018). *ATM Milano: electric buses are the present*, News item and interview, Sustainable Bus website. October 16<sup>th</sup> 2018.  
<https://www.sustainable-bus.com/interview/atm-milano-electric-buses-are-the-present/>
- [12] Hart, D., Howes, J. Madden, B. et al. (2016), *Hydrogen and fuel cells: opportunities for growth*, Report commissioned by Innovate UK, Department of Business, Energy and Industrial Strategy, Transport Scotland, Scottish Government, Scottish Enterprise, KTN, UKHFCA and SHFCA. E4tech and Element Energy.  
<http://www.e4tech.com/reports/hydrogen-and-fuel-cells-opportunities-for-growth-a-roadmap-for-the-uk/>
- [13] Hacker, V. and Mitsushima, S. (eds.) (2018). *Fuel Cells and Hydrogen: From Fundamentals to Applied Research*, Amsterdam, Elsevier.
- [14] Anonymous (2018), *Artemis: new tech cuts fuel emissions on trains*, Railway Technology website, 2nd July 2018  
<https://www.railway-technology.com/features/tech-fuel-emissions-trains/>
- [15] D. Gibson, “Tramway current demand”. *Tramways & Urban Transit*, No. 963, (March 2018): 98-99.
- [16] Wheals, J.C. To, W. Dalby, J. Vigar, M et al (2015). Viable flywheel system for rail, <http://www.artemisip.com/wp-content/uploads/2016/03/2015-04-Wheals-et-al-viable-flywheel.pdf>
- [17] Anonymous (2019). Digital displacement cuts energy use. *Railway Gazette International*, April 2019: 34-35. <http://www.artemisip.com/wp-content/uploads/2019/03/190325-Railway-Gazette-case-study.pdf>
- [18] Artemis Intelligent Power Ltd (2018). *Leading hydraulic power into the digital age; High efficiency auxiliary drive*, website <http://www.artemisip.com/wp-content/uploads/2018/10/Rail-applications.pdf>



- [19] Raza, W., Ali, F, Raza, N. et al. (2018). Recent advancements in supercapacitor technology, *Nano Energy*, 52: 441-473.  
<https://www.sciencedirect.com/science/article/pii/S2211285518305755>
- [20] Forse, A.C., Merlet, C., Griffin, J. M. and Grey, C.P. (2016), New perspectives on the charging mechanisms of supercapacitors. *J. Am. Chem. Soc.*, 138: 5731–5744.  
<https://pubs.acs.org/doi/full/10.1021/jacs.6b02115>
- [21] Douglas, H., Roberts, C., Hillmansen, S., and Schmid, F. (2015), An assessment of available measures to reduce traction energy use in railway networks, *Energy Conversion and Management*, 106: 1149-1165.  
[https://www.researchgate.net/publication/284130969\\_An\\_assessment\\_of\\_available\\_measures\\_to\\_reduce\\_traction\\_energy\\_use\\_in\\_railway\\_networks/citation/download](https://www.researchgate.net/publication/284130969_An_assessment_of_available_measures_to_reduce_traction_energy_use_in_railway_networks/citation/download)
- [22] Douglas, H., Schmid, F., Roberts, C. and Hillmansen S., 2016c. Evaluation of Permanent Magnet Motor Energy Saving Technology for Different Types of Railways, In: *Proceedings IEEE International Conference on Intelligent Rail Transportation*. Birmingham, UK, 23-25 August 2016. New York: IEEE
- [23] Steele, H.J. (2017), Finding Solutions for Complex Systems: Saving Traction Energy in Rail, PhD thesis, Birmingham Centre for Rail Research and Education, University of Birmingham,  
<https://pdfs.semanticscholar.org/flc5/ac9efae4f48bf80bc26607886e3b836e56ef7.pdf>
- [24] Douglas, H., Weston, P., Kirkwood, D., Hillmansen, S. and Roberts, C., (2017), Method for validating the train motion equations used for passenger rail vehicle simulation, *Proc IMechE Part F: J Rail and Rapid Transit*, 231(4): 455-469.  
<https://journals.sagepub.com/doi/abs/10.1177/0954409716631784>
- [25] Varma, N.E.V.R.D., Vaishnav, R. and Mittal, A. (2015). A review of energy sources and power converters for electrified vehicles. *International Journal of Renewable Energy and Environmental Engineering*, 3 (1): 44-51.  
[https://www.academia.edu/16189072/A\\_review\\_of\\_energy\\_sources\\_and\\_power\\_converters\\_for\\_electrified\\_vehicles](https://www.academia.edu/16189072/A_review_of_energy_sources_and_power_converters_for_electrified_vehicles)
- [26] Murray-Smith, D. J. (2018). *Aberdeen to Ballater by BMU: notes on the battery railcar experiment*, Article, Railscot website.  
[https://www.railscot.co.uk/articles/Aberdeen\\_to\\_Ballater\\_by\\_BMU:\\_Notes\\_on\\_the\\_Battery\\_Railcar\\_Experiment/](https://www.railscot.co.uk/articles/Aberdeen_to_Ballater_by_BMU:_Notes_on_the_Battery_Railcar_Experiment/)
- [27] Anonymous (2015). Battery-powered train wins industry award for innovation. Network Rail Media Centre News Report. 30<sup>th</sup> June 2015.  
<https://www.networkrailmediacentre.co.uk/news/battery-powered-train-wins-industry-award>
- [28] Anonymous (2019) Vivarail battery hybrid trials underway, *The Railway Magazine*, October 2019, 165 (1423): 105.
- [29] Anonymous (2018). BatteryFLEX Desiro EMU conversion proposed. *Railway Gazette*. 15 October 2018. <https://www.railwaygazette.com/uk/batteryflex-desiro-emu-conversion-proposed/47363.article> .
- [30] Shirres, D (2019). *Hitachi plans to run ScotRail Class 385 EMUs beyond the wires*. Rail Engineer website. 26<sup>th</sup> March 2019. <https://www.railengineer.co.uk/2019/03/26/hitachi-plan-to-run-scotrail-class-385-emus-beyond-the-wires/>
- [31] Anonymous (2018). ÖBB and Bombardier sign call-off order for 25 TALENT 3 trains. *Global Railway Review*, 3<sup>rd</sup> July 2018.  
<https://www.globalrailwayreview.com/news/70893/obb-bombardier-25-talent-3-trains/>
- [32] Anonymous (2018). New Tyne & Wear fleet to have ‘battery boost’, *Tramways and Urban Transit*, March 2018: 84.
- [33] Anonymous (2019). West Midland Metro chooses CAF, *Tramways & Urban Transit*, November 2019, No 98: 405.

- [34] Anonymous (2019). Birmingham battery tram gets test run, *The Railway Magazine*, October 2019, 165 (1423): 86.
- [35] Anonymous (2019). Next generation tramways: Nice, *Tramways and Urban Transit*, September 2019:342-344.
- [36] Shirres, D. and Baxter J. (2019). *The future of hydrogen trains in the UK*, Report, Institution of Mechanical Engineers, London. <https://www.imeche.org/policy-and-press/reports/detail/the-future-for-hydrogen-trains-in-the-uk>
- [37] Butterworth, S., Hill, N. and Kollamthodi, S. (2005). *Feasibility study into the use of hydrogen fuel*, RSSB Report, T531-Final Report, Rail Safety & Standards Board, U.K. <https://www.rssb.co.uk/research-development-and-innovation/research-reports-catalogue/pb009661>
- [38] Hoffrichter, A. Hillmansen, S. and Roberts, C (2016). Conceptual propulsion system design for a hydrogen-powered regional train. *IET Electrical Systems in Transportation*, 6 (2): 56–66. [http://pure-oai.bham.ac.uk/ws/files/21857765/Hoffrichter\\_Hillmansen\\_Roberts\\_2015\\_Conceptual\\_propulsion\\_system\\_IET.pdf](http://pure-oai.bham.ac.uk/ws/files/21857765/Hoffrichter_Hillmansen_Roberts_2015_Conceptual_propulsion_system_IET.pdf)
- [39] Kent, S. (2016) *Future Railway Powertrain Challenge: Fuel-Cell electric Multiple Unit (FCEMU) Project – Phase 1 Report- Issue 1*. University of Birmingham, Hitachi Rail, Fuel Cell Systems Ltd. June 2016. <https://www.birmingham.ac.uk/Documents/college-eps/railway/1-Class-156-Fuel-Cell-Electric-Multiple-Unit-Feasibility-Study-Issue-1.pdf>
- [40] Anonymous (2019). *Alstom will supply 41 Coradia Lint regional trains to Bavaria, Germany*. Press release, Alstom, 20th March 2019. <https://www.alstom.com/press-releases-news/2019/3/alstom-will-supply-41-coradia-lint-regional-trains-bavaria-germany>
- [41] Anonymous (2018). *University of Birmingham signs joint initiative to develop HydroFlex – the UK's first hydrogen train*. News item. University of Birmingham website. 21<sup>st</sup> September 2018. <https://www.birmingham.ac.uk/news/latest/2018/09/joint-initiative-to-develop-hydroflex-the-uks-first-hydrogen-train.aspx>
- [42] Anonymous (2019). *New hydrogen ‘Breeze’ trains unveiled by Alstom and Eversholt*. Rail Technology Magazine, 17<sup>th</sup> January 2019. <http://www.railtechnologymagazine.com/Rail-News/new-hydrogen-breeze-trains-unveiled-by-alstom-and-everholt>
- [43] Barrow, K (2019), Vivarail forms hydrogen fuel-cell partnership, *International Rail Journal*, May 8th 2019. <https://www.railjournal.com/fleet/vivarail-forms-hydrogen-fuel-cell-partnership/>
- [44] Anonymous (2019). News item, *Tramways and Urban Transit* No. 925, Sept 2019: 330-336.
- [45] Anonymous (2019), News item, *Today's Railways Europe* No. 285, September 2019: 44.
- [46] Reidinger, E, (2019), Zillertalbahn hydrogen train design revealed, *International Railway Journal*, February 18, 2019. <https://www.railjournal.com/fleet/zillertalbahn-hydrogen-train-design-revealed/>
- [47] Anonymous (2019), 27 iLINT for Hessen. *Today's Railways Europe*, July 2019, Issue 283: 6.
- [48] Ianuzzi, D., Lauria, D. and Tricoli, P. (2012). Optimal design of stationary supercapacitors storage devices for light electrical transportation systems. *Optimization and Engineering* 13: 689–704. [https://www.researchgate.net/publication/225700771\\_Optimal\\_design\\_of\\_stationary\\_supercapacitors\\_storage\\_devices\\_for\\_light\\_electrical\\_transportation\\_systems/download](https://www.researchgate.net/publication/225700771_Optimal_design_of_stationary_supercapacitors_storage_devices_for_light_electrical_transportation_systems/download)

- [49] Gao, Z., Fang, J., Zhang, Y. and Sun D (2014). Control strategy for wayside supercapacitor energy storage system in railway transit network. *J. Mod. Power Syst. Clean Energy*, 2(2): 181–190. <https://core.ac.uk/download/pdf/81205825.pdf>
- [50] Iannuzzi, D. and Tricoli, P. (2012) Speed-based state-of-charge tracking control for metro trains with onboard supercapacitors, *IEEE Transactions on Power Electronics*, 27 (4): 2129-2139. [https://www.researchgate.net/profile/D\\_Iannuzzi/publication/241639227\\_Speed-Based\\_State\\_of\\_Charge\\_Tracking\\_Control\\_for\\_Metro\\_Trains\\_With\\_Onboard\\_Supercapacitors/links/57f2359008ae91deaa562aac/Speed-Based-State-of-Charge-Tracking-Control-for-Metro-Trains-With-Onboard-Supercapacitors.pdf](https://www.researchgate.net/profile/D_Iannuzzi/publication/241639227_Speed-Based_State_of_Charge_Tracking_Control_for_Metro_Trains_With_Onboard_Supercapacitors/links/57f2359008ae91deaa562aac/Speed-Based-State-of-Charge-Tracking-Control-for-Metro-Trains-With-Onboard-Supercapacitors.pdf)
- [51] Khodaparastan, M., Dutta, O., Saleh, M. and Mohamed, A.A.(2019). Modeling and simulation of dc electric rail transit systems with wayside energy storage. *IEEE Transactions on Vehicular Technology*, 68 (3): 2218-2228. [https://www.researchgate.net/publication/330640996\\_Modeling\\_and\\_Simulation\\_of\\_DC\\_Electric\\_Rail\\_Transit\\_Systems\\_With\\_Wayside\\_Energy\\_Storage](https://www.researchgate.net/publication/330640996_Modeling_and_Simulation_of_DC_Electric_Rail_Transit_Systems_With_Wayside_Energy_Storage)
- [52] Ruigang, S., Yuan, T.-C., Jian, Y. and Hao, H. (2017). Simulation of braking energy recovery for the metro vehicles based on the traction experiment system. *Simulation: Transactions of the Society for Modeling and Simulation International*, 2: 1099-1112. [https://www.researchgate.net/publication/319220691\\_Simulation\\_of\\_braking\\_energy\\_recovery\\_for\\_the\\_metro\\_vehicles\\_based\\_on\\_the\\_traction\\_experiment\\_system](https://www.researchgate.net/publication/319220691_Simulation_of_braking_energy_recovery_for_the_metro_vehicles_based_on_the_traction_experiment_system)
- [53] Anonymous (2018). Wuhan opens its second tramway. *Tramways and Urban Transit*, March 2018, No. 963: 84.
- [54] Anonymous (2019) South Wales Metro: The transformation begins, *Tramways & Urban Transit*, October 2019, No 982: 369-373.
- [55] Anonymous (2019) Foshan fuel cell tramway enters final testing stage, *Tramways & Urban Transit*, December 2019, No 984: 445.
- [56] Anonymous (2019). University of Birmingham leases HST as R&D testbed. *The Railway Magazine*, October 2019, 165 (1423): 6.
- [57] Ford, R. (2019). Freight diesel traction realities. *Modern Railways*, 76(847): 22-30.